



## 490S-T STROBE

### Hazardous Location Warning Light

The model 490S-1280T and 490S-120T strobe lights are UL listed for use in Class I & II, Division 2 hazardous locations. Division 2 locations are defined by the NFPA as shown below. These units have a Lexan® lens and base and are suitable for use in NEMA 4X outdoor locations. They may be operated in any position and feature a 1/2" pipe mount hub.

- Class I, Div. 2 Groups A, B, C, & D
- Class II, Div 2 Groups F & G
- Class III
- NEMA 4X
- 10,000 hour strobe lamp
- ten year warranty on power supply
- available in six lens colors
- UL listed

Lens Colors



#### Ordering Information

Please specify lens colors and model number when ordering. Available colors are Amber, Blue, Clear, Green and Red.

Model No.	Description	Voltage
490S-1280T	Hazardous location strobe	12 – 80VDC
490S-120T	Hazardous location strobe	120VAC

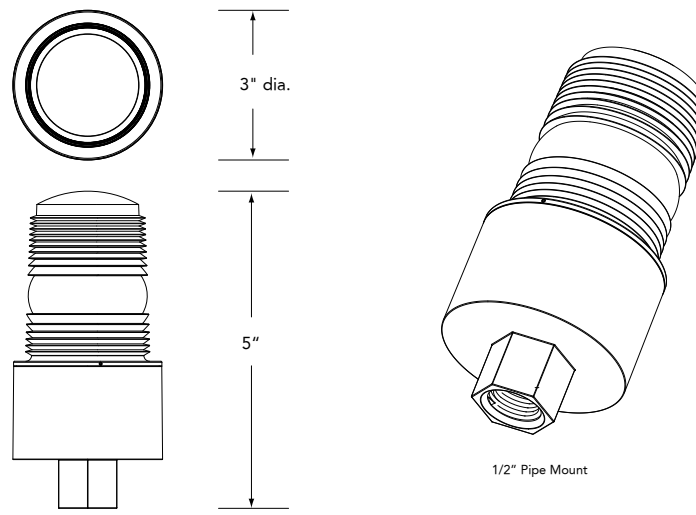

## NFPA Definitions

### Class I, Division 2.

A location (1) in which volatile flammable liquids or flammable gases are handled, processed or used, but in which the liquids, vapors or gases will normally be confined within closed containers or closed systems from which they can escape only in case of accidental rupture or breakdown of such containers or systems, or in case of abnormal operation of equipment; or (2) in which ignitable concentrations of gases or vapors are normally prevented by positive mechanical ventilation, and which might become hazardous through failure or abnormal operation of the ventilating equipment; or (3) that is adjacent to a Class I Division 1 location, and to which ignitable concentrations of gases or vapors might occasionally be communicated unless such communication is prevented by adequate positive-pressure ventilation from a source of clean air and effective safeguards against ventilation failure are provided. [See Section 500-4(b) of NFPA 70, National Electrical Code.]

### Class II, Division 2.

A location in which (1) combustible dust will not normally be in suspension in the air in quantities sufficient to produce explosive or ignitable mixtures and dust accumulations are normally insufficient to interfere with the normal operation of electrical equipment or other apparatus; or (2) dust may be in suspension in the air as a result of infrequent malfunctioning of handling or processing equipment and dust accumulations resulting therefrom may be ignitable by abnormal operation or failure of electrical equipment or other apparatus. [See Section 500-5 (b) of NFPA 70, National Electrical Code.]

## Specifications

Item	Description
Lamp Type	5001 Xenon strobe lamp
Lens Type	470S-L-Color ( please specify lens color )
Voltage and Amperage	12-80VDC draws 0.4A average @ 12VDC draws tapering to 0.05A average @ 80VDC 16-24VAC draws 0.35A average 120VAC draws 0.04A average
Temperature Code	Class I T2C 230° C Do not install where the operating temperature exceeds the ignition temperature of the hazardous atmosphere.
Temperature Rating	-40° C to +65° C
Power Supply Output 2.7 Watts ( single flash )	2.3 joules per flash
Flash Rate	60 to 80 flashes per minute
Size and Weight	5" tall x 3" dia. x 0.6 lbs ( 127mm x 76mm x 0.27kg )
Encapsulation	Fully potted in urethane material with no exposure to High Voltage possible

### Architect and Engineer Specifications

Hazardous Location visual signaling beacon shall be Tomar model number series 490S-1280T, 490S-120T or approved equal. The beacon shall be UL Listed Class I, Division II, Groups A,B,C, and D; Class II, Division II, Groups F and G; and Class III for use in specified hazardous locations as classified by the National Electric Code. The light source shall be a plug-in field replaceable single-flash xenon strobe lamp. The warning signal must have built-in RFI filters to protect against radio interference and spike voltages. It shall be polarity protected, and have a power supply fully potted in polyurethane. Voltage ranges shall be 12-80VDC or 120 VAC. The warning light shall be rated NEMA 4X and have a screw-on Lexan® lens.