

INSTRUCTION SHEET

HK-CV92 HOOK KIT

INSTALLER SAFETY MESSAGE

The safe installation of the Tomar 930 HELIOBE Light Bar is your first priority. All instructions listed here should be followed and common sense applied to each Light Bar installation to insure safety. Tomar field service should be called if you have any question.

Some important precautions and instructions:

- Installers should have a good understanding of automotive electrical and mechanical systems. The quality of the installation work should equal or surpass OEM standards.
- Protect the vehicle components when drilling into the sheet metal. Metal chips and sharp edges must not be left on the vehicle. Check to see that the drill bit will not damage surrounding components when it penetrates the sheet metal.
- Review all instruction sheets packed with other components of the 930 HELIOBE Light Bar and make sure you thoroughly understand each step of the installation before you start.
- Roof damage can occur if mounting bolts are over tightened.
- File these instructions in a safe place for future reference.

Perform a final inspection of the installation to insure that the 930 HELIOBE Light Bar is operating properly. It should be securely fastened to the vehicle when pulling on the Light Bar mounting bracket. Failure to follow all safety procedures and instructions may result in serious injury, property damage or death to you or others.

I. GENERAL INFORMATION

This instruction sheet provides procedures to install the HK-CV92 mounting hook to the Tomar 930 HELIOBE Light Bar and mount the assembly to the 1992 Ford Crown Victoria. In order to complete the installation, you must have purchased the 930 HELIOBE Light Bar with the your specific lamp configuration and a 930-UNHK Mounting Kit.

II. UNPACKING

Check to see that all components listed shown in figure 1 are included.

III. ASSEMBLY

- A. Read and understand all assembly instructions included with the 930-UNHK Mounting Kit and the other 930 HELIOBE Light Bar components.
- B. Place the light bar on the vehicle roof. The unit is usually located approximately over the drivers head with the hook located above or near the center door post. **CAUTION** Water may leak into the vehicle if the hook is improperly positioned.

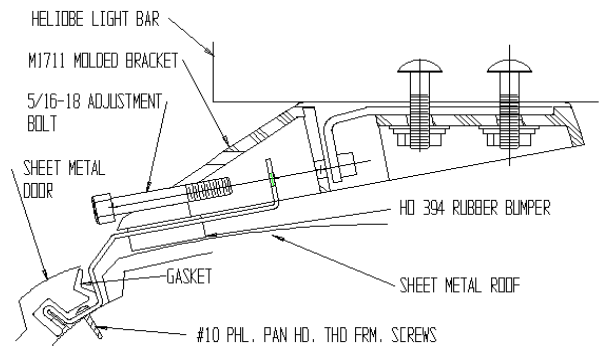

Figure 1

- C. Slide the door gutter gasket off the sheet metal just enough to position the hook. Using the hook as a template, mark the two screw hole locations and drill two (2) .147 dia. holes (#26 drill bit).
- D. Apply silicon sealant (not supplied) around the holes before attaching the hook. Secure with the two sheet metal screws provided (#10 thread forming).
- C. Insert the hook into the opening in the center of the left mounting bracket and position it over the door gasket.
- F. Assemble the hook to the mounting bracket using one of the three 5/16 stainless adjusting bolts that best fits your installation. Tighten the bolt finger tight. Repeat with the right mounting bracket.
- E. Tighten both 5/16 stainless adjusting bolts equally, enough to prevent the light bar from sliding front-to-back when pulling on the mounting bracket.
- E. Reinstall the door gutter gaskets over the roof sheet metal and the hook.
- K. Inspect the entire assembly to insure that all fasteners and brackets are tight.

